

AIR CONDITIONER

**Duct type**

## DESIGN & TECHNICAL MANUAL

---

---

INDOOR



ARXG36KHTAP  
ARXG45KHTAP  
ARXG54KHTAP

---

OUTDOOR



AOYG36KRTA



AOYG45KRTA  
AOYG54KRTA

---

**Notices:**

- Product specifications and design are subject to change without notice for future improvement.
- For further details, please check with our authorized dealer.

**Trademarks**

FGLair™ is trademark of Fujitsu General Limited in the United States, other countries or both.

Google Play™ is trademark of Google Inc.

App Store® is a service mark of Apple Inc., registered in the U.S. and other countries.

## CONTENTS (continued)

---

<b>Part 2. OUTDOOR UNIT</b> .....	<b>43</b>
<b>1. Specifications</b> .....	<b>44</b>
<b>2. Dimensions</b> .....	<b>46</b>
2-1. Models: AOYG36KRTA .....	46
2-2. Models: AOYG45KRTA and AOYG54KRTA.....	47
<b>3. Installation space</b> .....	<b>48</b>
3-1. Models: AOYG36KRTA, AOYG45KRTA, and AOYG54KRTA.....	48
<b>4. Refrigerant circuit</b> .....	<b>51</b>
4-1. Models: AOYG36KRTA, AOYG45KRTA, and AOYG54KRTA.....	51
<b>5. Wiring diagrams</b> .....	<b>52</b>
5-1. Model: AOYG36KRTA .....	52
5-2. Models: AOYG45KRTA and AOYG54KRTA.....	52
<b>6. Capacity compensation rate for pipe length and height difference</b> .....	<b>53</b>
6-1. Model: AOYG36KRTA .....	53
6-2. Models: AOYG45KRTA and AOYG54KRTA.....	54
<b>7. Additional charge calculation</b> .....	<b>55</b>
7-1. Model: AOYG36KRTA .....	55
7-2. Models: AOYG45KRTA and AOYG54KRTA.....	55
<b>8. Airflow</b> .....	<b>56</b>
8-1. Models: AOYG36KRTA .....	56
8-2. Models: AOYG45KRTA and AOYG54KRTA.....	56
<b>9. Operation noise (sound pressure)</b> .....	<b>57</b>
9-1. Noise level curve.....	57
9-2. Sound level check point .....	58
<b>10. Electrical characteristics</b> .....	<b>59</b>
<b>11. Safety devices</b> .....	<b>60</b>
<b>12. External input and output</b> .....	<b>61</b>
12-1.External input .....	61
12-2.External output.....	63
<b>13. Function settings</b> .....	<b>65</b>
13-1.Control PCB and switch buttons location .....	65
13-2.Local setting procedure.....	67
<b>14. Accessories</b> .....	<b>69</b>
14-1.Models: AOYG36KRTA, AOYG45KRTA, and AOYG54KRTA.....	69
<b>15. Optional parts</b> .....	<b>70</b>

# **Part 2. OUTDOOR UNIT**

---

**SINGLE TYPE:**

**AOYG36KRTA**

**AOYG45KRTA**

**AOYG54KRTA**

# 1. Specifications

Type				Inverter heat pump	
<b>Model name</b>				<b>AOYG36KRTA</b>	
Power supply				3N 400 V ~ 50 Hz	
Power supply intake				Outdoor unit	
Available voltage range				342—457 V	
Starting current				5.5	
Fan	Airflow rate	Cooling	m <sup>3</sup> /h	3,750	
		Heating		3,750	
	Type × Q'ty			Propeller × 1	
	Motor output		W	100	
Sound pressure level *1		Cooling	dB (A)	55	
		Heating		55	
Sound power level		Cooling	dB (A)	70	
		Heating		70	
Heat exchanger type	Dimensions (H × W × D)		mm	Main1: 756 × 905 × 18.20	
				Main2: 756 × 905 × 18.20	
	Fin pitch				Main1: 1.45
					Main2: 1.45
	Rows × Stages				Main1: 1 × 36
					Main2: 1 × 36
Pipe type				Copper	
Fin	Type (Material)			Aluminum	
	Surface treatment			Blue fin	
Compressor	Type × Q'ty			DC Twin rotary × 1	
	Motor output	W		1,500	
Refrigerant	Type (Global warming potential)			R32 (675)	
	Factory charge	g		1,900	
Refrigerant oil	Type			FW68D	
	Amount	cm <sup>3</sup>		600	
Enclosure	Material			Steel sheet	
	Color			Beige	
				Approximate color of Munsell 10YR 7.5/1.0	
Dimensions (H × W × D)	Net		mm	788 × 940 × 320	
	Gross			966 × 1,027 × 445	
Weight	Net		kg	53	
	Gross			62	
Connection pipe	Size	Liquid	mm (in)	Ø 9.52 (3/8)	
		Gas		Ø 15.88 (5/8)	
	Method				Flare
	Pre-charge length				30
	Max. length		m		50
	Max. height difference			30	
Operation range		Cooling	°C	-15 to 46	
		Heating		-15 to 24	
Drain hose	Material			LDPE	
	Size	mm		Ø 13.0 (I. D.), Ø 16.0 to Ø 16.7 (O. D.)	

**NOTES:**

- Specifications are based on the following conditions:
  - Cooling: Indoor temperature of 27 °CDB/19 °CWB, and outdoor temperature of 35 °CDB/24 °CWB.
  - Heating: Indoor temperature of 20 °CDB/15 °CWB, and outdoor temperature of 7 °CDB/6 °CWB.
  - Pipe length: 5.0 m, Height difference: 0 m. (Between outdoor unit and indoor unit.)
- Protective function might work when using it outside the operation range.
- \*1: Sound pressure level
  - Measured values in manufacturer's anechoic chamber.
  - Because of the surrounding sound environment, the sound levels measured in actual installation conditions might be higher than the specified values here.

Type				Inverter heat pump			
Model name				AOYG45KRTA		AOYG54KRTA	
Power supply				3N 400 V ~ 50 Hz			
Power supply intake				Outdoor unit			
Available voltage range				342—457 V			
Starting current				6.6		8.0	
Fan	Airflow rate	Cooling	m <sup>3</sup> /h	4,450			
		Heating		4,450			
	Type × Q'ty				Propeller × 1		
Motor output			W	120			
Sound pressure level *1		Cooling	dB (A)	57			
		Heating		57		59	
Sound power level		Cooling	dB (A)	71		73	
		Heating		71		73	
Heat exchanger type		Dimensions (H × W × D)		mm	Main1: 966 × 905 × 18.20		
		Fin pitch			Main2: 966 × 905 × 18.20		
					Sub: 966 × 543 × 18.20		
		Rows × Stages			Main1: 1.45		
					Main2: 1.45		
		Sub: 1.45					
		Main1: 1 × 46					
		Main2: 1 × 46					
		Sub: 1 × 46					
Pipe type		Copper					
Fin		Type (Material)	Aluminum				
		Surface treatment	Blue fin				
Compressor		Type × Q'ty	DC Twin rotary × 1				
		Motor output	W				
		2,180					
Refrigerant		Type (Global warming potential)		R32 (675)			
		Factory charge		g			
		2,700					
Refrigerant oil		Type		RmM68AF			
		Amount		cm <sup>3</sup>			
		800					
Enclosure		Material		Steel sheet			
		Color		Beige			
		Approximate color of Munsell 10YR 7.5/1.0					
Dimensions (H × W × D)		Net		mm	998 × 940 × 320		
		Gross			1,176 × 1,027 × 445		
Weight		Net		kg	67		
		Gross			77		
Connection pipe		Size		mm (in)	Ø 9.52 (3/8)		
					Ø 15.88 (5/8)		
		Method		Flare			
		Pre-charge length		m	30		
		Max. length			50		
Max. height difference		30					
Operation range		Cooling	°C	-15 to 46			
		Heating		-15 to 24			
Drain hose		Material		LDPE			
		Size		mm			
		Ø 13.0 (I. D.), Ø 16.0 to Ø 16.7 (O. D.)					

**NOTES:**

- Specifications are based on the following conditions:
  - Cooling: Indoor temperature of 27 °CDB/19 °CWB, and outdoor temperature of 35 °CDB/24 °CWB.
  - Heating: Indoor temperature of 20 °CDB/15 °CWB, and outdoor temperature of 7 °CDB/6 °CWB.
  - Pipe length: 5.0 m, Height difference: 0 m. (Between outdoor unit and indoor unit.)
- Protective function might work when using it outside the operation range.
- \*1: Sound pressure level
  - Measured values in manufacturer's anechoic chamber.
  - Because of the surrounding sound environment, the sound levels measured in actual installation conditions might be higher than the specified values here.

## 2. Dimensions

### 2-1. Models: AOYG36KRTA

Unit: mm

OUTDOOR UNIT  
AOYG36-54KRTA

OUTDOOR UNIT  
AOYG36-54KRTA

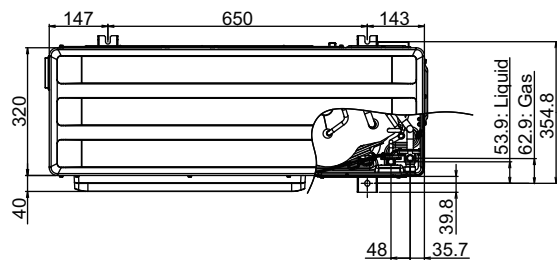

Top view

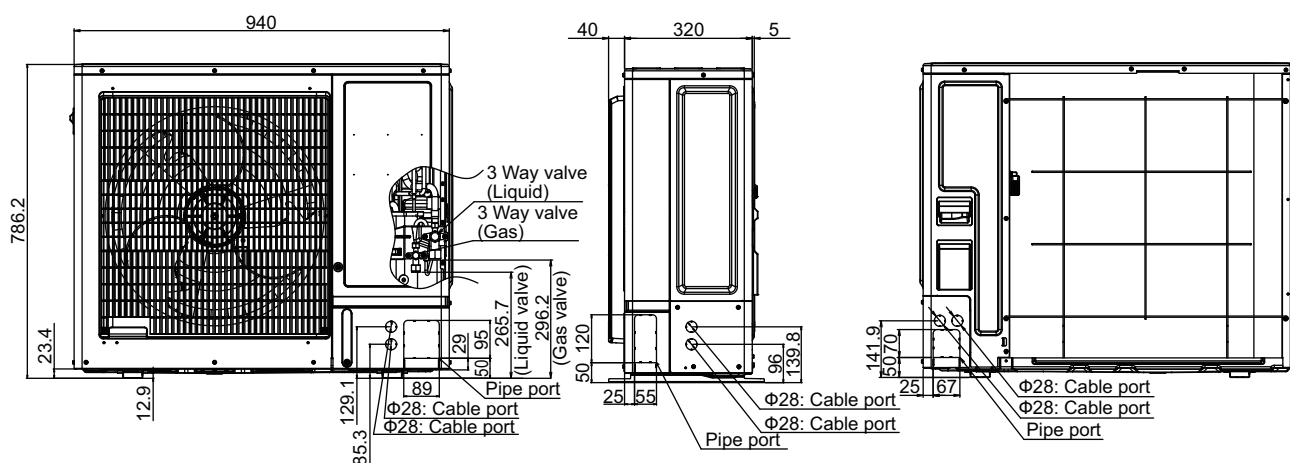

Front view

Side view

Rear view

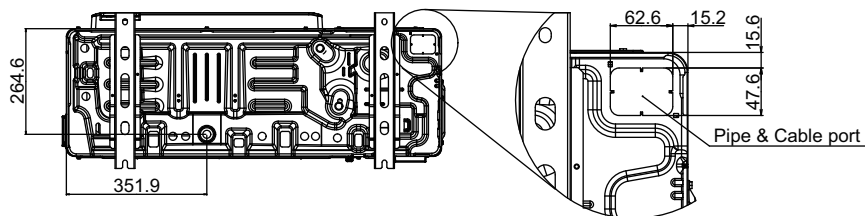

Bottom view

# 2-2. Models: AOYG45KRTA and AOYG54KRTA

Unit: mm

OUTDOOR UNIT  
AOYG36-54KRTA

OUTDOOR UNIT  
AOYG36-54KRTA

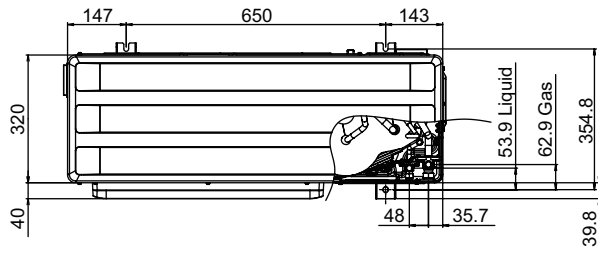

Top view

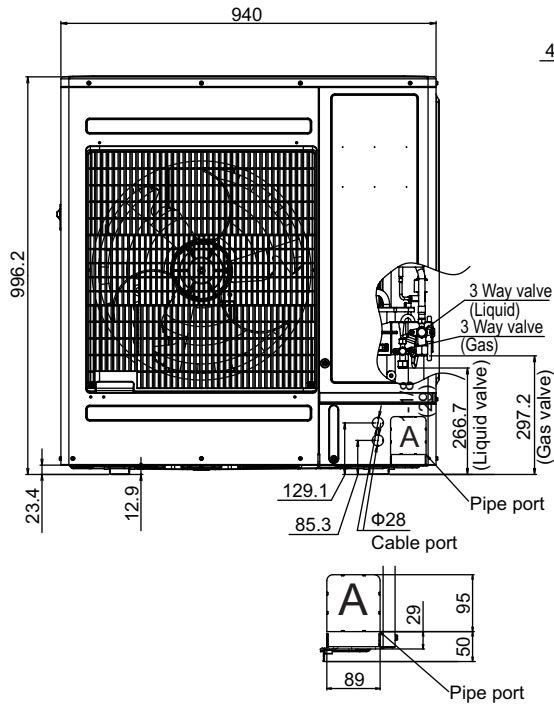

Front view

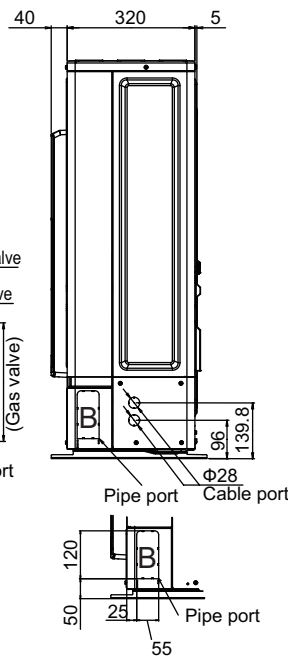

Side view

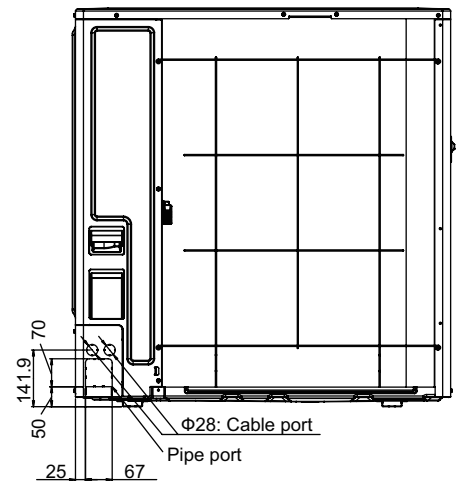

Rear view

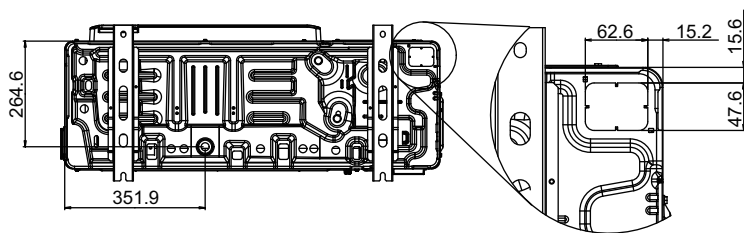

Bottom view

Pipe & Cable port



### 3. Installation space

#### 3-1. Models: AOYG36KRTA, AOYG45KRTA, and AOYG54KRTA

##### ■ Space requirement

Provide sufficient installation space for product safety.

##### ● Single outdoor unit installation

- When the upper space is open:

Unit: mm

When there are obstacles at the rear only.

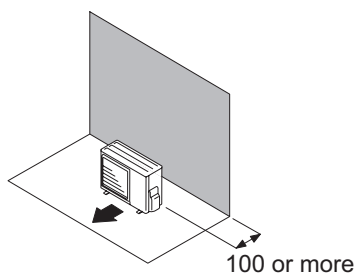

When there are obstacles at the rear and sides.

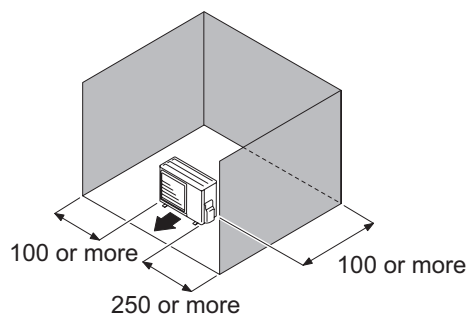

When there are obstacles at the front only.

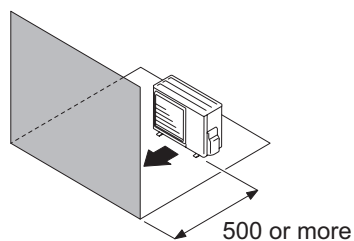

When there are obstacles at the front and rear.

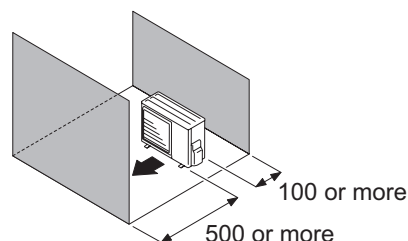

- When there is an obstruction in the upper space:

Unit: mm

When there are obstacles at the rear and above.

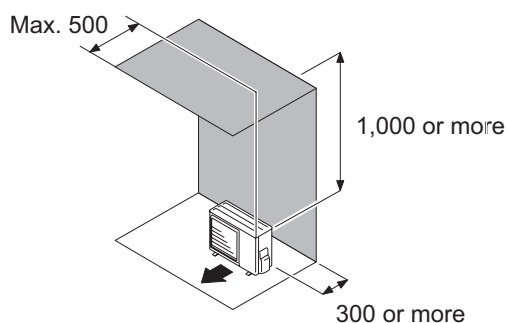

When there are obstacles at the rear, sides, and above.

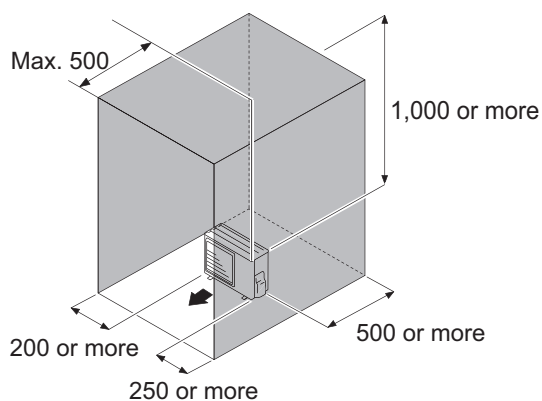

## ● Multiple outdoor unit installation

- When the upper space is open:

Unit: mm

When there are obstacles at the rear only.

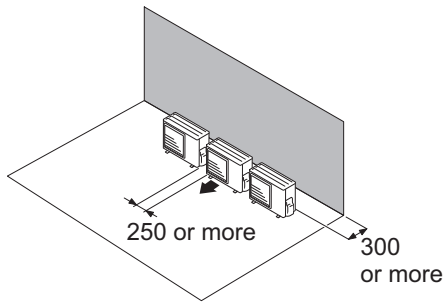

When there are obstacles at the front only.

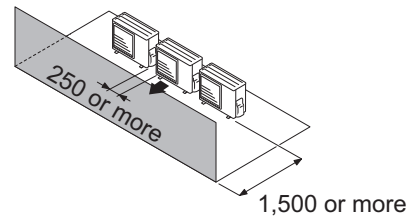

When there are obstacles at the front and rear.

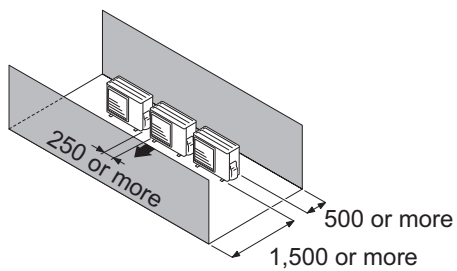

- When there is an obstruction in the upper space:

Unit: mm

When there are obstacles at the rear and above.

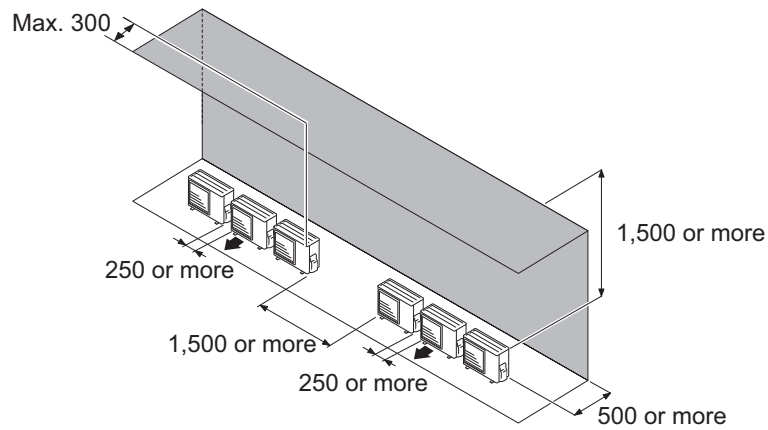

OUTDOOR UNIT  
AOYG36-54KRTA

OUTDOOR UNIT  
AOYG36-54KRTA

## ● Outdoor unit installation in multi-row

Unit: mm

Single parallel unit arrangement

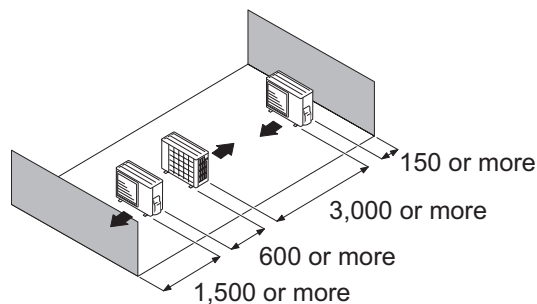

Multiple parallel unit arrangement

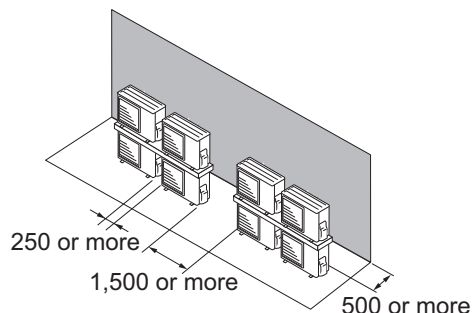
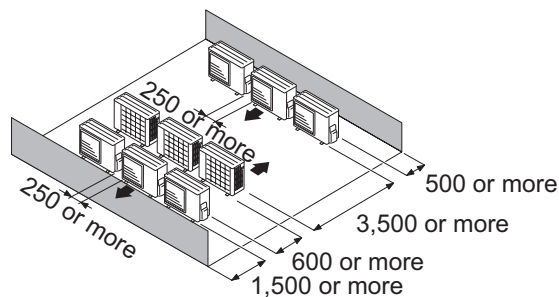

### NOTES:

- If the space is larger than stated above, the condition will be the same as when there is no obstacle.
- Height above the floor level should be 50 mm or more.
- When installing the outdoor unit, be sure to open the front and left side to obtain better operation efficiency.

### ⚠ CAUTION

- Do not install the outdoor unit in two-stage where the drain water could freeze. Otherwise the drainage from the upper unit may form ice and cause a malfunction of the lower unit.
- When the outdoor temperature is 0 °C or less, do not use the accessory drain pipe and drain cap. If the drain pipe and drain cap are used, the drain water in the pipe may freeze in extremely cold climate. (For reverse cycle model only.)
- In area with heavy snowfall, if the inlet and outlet of the outdoor unit is blocked with snow, it might become difficult to get warm, and it is likely to cause product malfunction. Construct a canopy and a pedestal, or place the unit on a high stand that is locally installed.

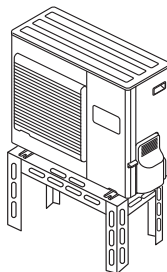

## 4. Refrigerant circuit

### 4-1. Models: AOYG36KRTA, AOYG45KRTA, and AOYG54KRTA

OUTDOOR UNIT  
AOYG36-54KRTA

OUTDOOR UNIT  
AOYG36-54KRTA

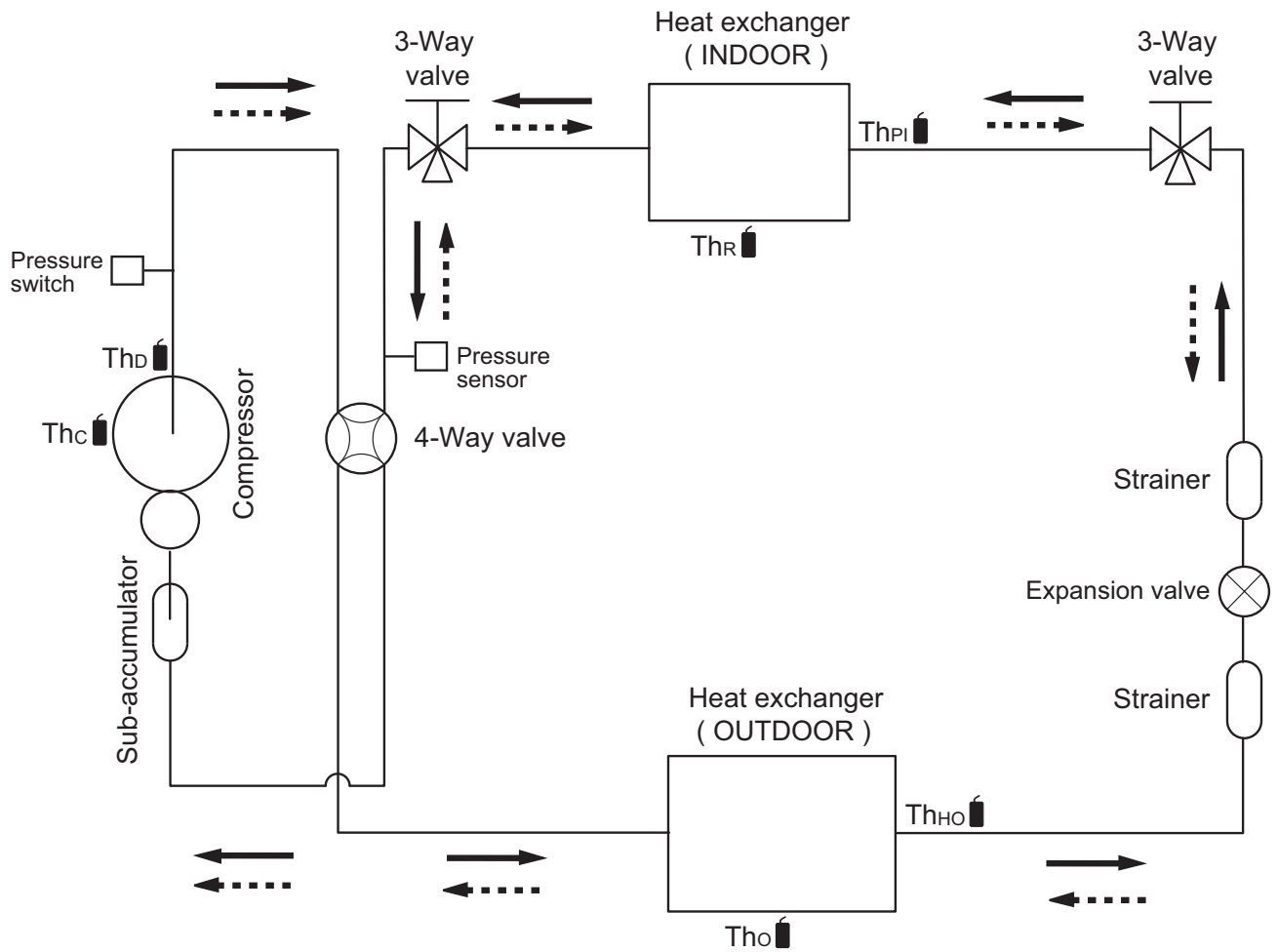

—→ : Cooling  
 - - - - -→ : Heating

- Th<sub>c</sub> : Thermistor (Compressor temperature)
- Th<sub>D</sub> : Thermistor (Discharge temperature)
- Th<sub>o</sub> : Thermistor (Outdoor temperature)
- Th<sub>HO</sub> : Thermistor (Heat Exchanger Out temperature)
- Th<sub>R</sub> : Thermistor (Room temperature)
- Th<sub>PI</sub> : Thermistor (Pipe temperature)

# 5. Wiring diagrams

## 5-1. Model: AOYG36KRTA

OUTDOOR UNIT  
AOYG36-54KRTA

OUTDOOR UNIT  
AOYG36-54KRTA

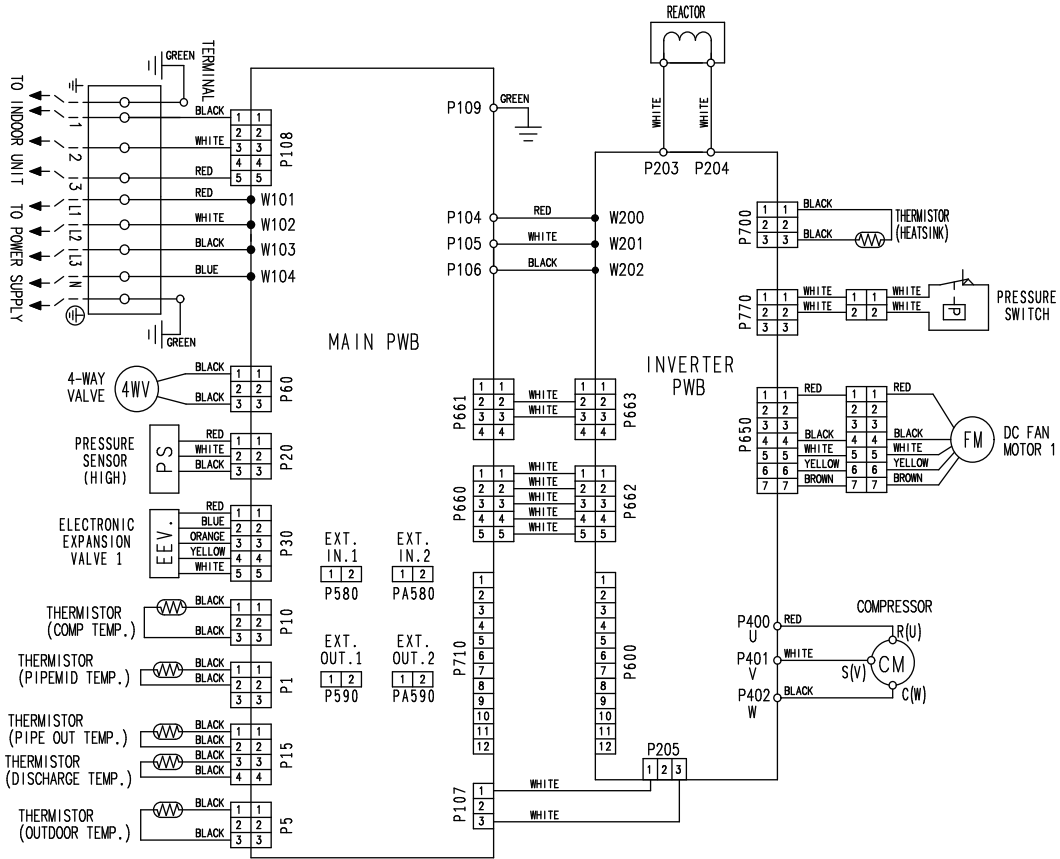

## 5-2. Models: AOYG45KRTA and AOYG54KRTA

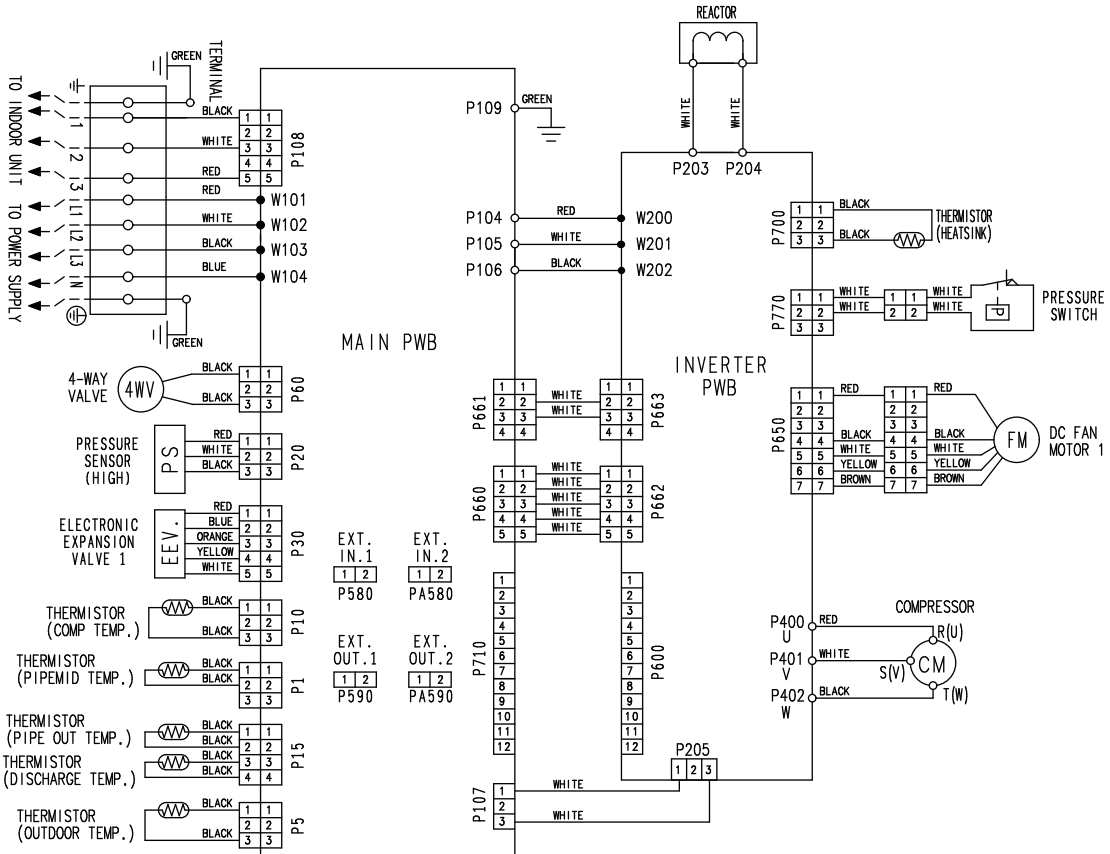

## 6. Capacity compensation rate for pipe length and height difference

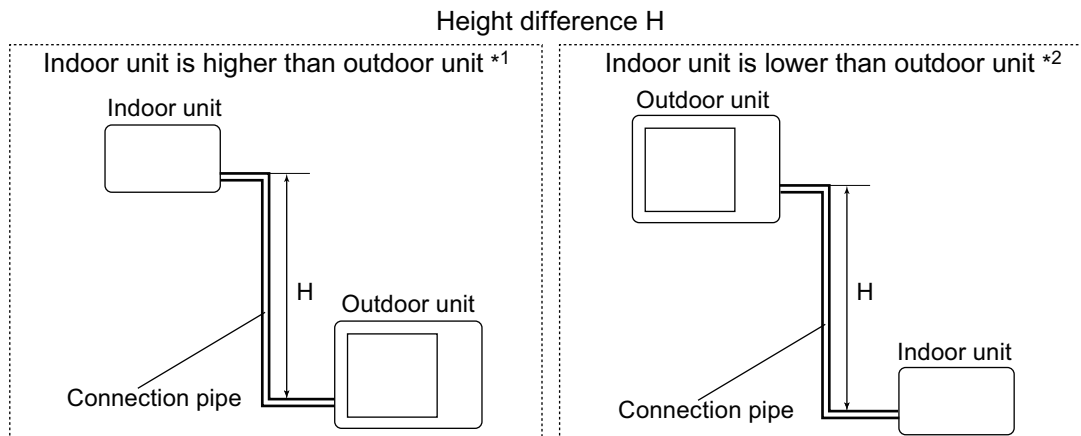

### 6-1. Model: AOYG36KRTA

**NOTE:** Values mentioned in the table are calculated based on the maximum capacity.

COOLING			Pipe length (m)						
			5	7.5	10	20	30	40	50
Height difference H (m)	Indoor unit is higher than outdoor unit *1	30	—	—	—	—	0.902	0.882	0.862
		20	—	—	—	0.938	0.917	0.897	0.876
		10	—	—	0.973	0.953	0.933	0.912	0.891
		7.5	—	0.988	0.977	0.957	0.936	0.916	0.895
		5	0.992	0.992	0.981	0.961	0.940	0.919	0.898
	Indoor unit is lower than outdoor unit *2	0	1.000	1.000	0.989	0.968	0.947	0.926	0.905
		-5	1.000	1.000	0.989	0.968	0.947	0.926	0.905
		-7.5	—	1.000	0.989	0.968	0.947	0.926	0.905
		-10	—	—	0.989	0.968	0.947	0.926	0.905
		-20	—	—	—	0.968	0.947	0.926	0.905
		-30	—	—	—	—	0.947	0.926	0.905

HEATING			Pipe length (m)						
			5	7.5	10	20	30	40	50
Height difference H (m)	Indoor unit is higher than outdoor unit *1	30	—	—	—	—	0.978	0.968	0.958
		20	—	—	—	0.988	0.978	0.968	0.958
		10	—	—	0.998	0.988	0.978	0.968	0.958
		7.5	—	1.000	0.998	0.988	0.978	0.968	0.958
		5	1.000	1.000	0.998	0.988	0.978	0.968	0.958
	Indoor unit is lower than outdoor unit *2	0	1.000	1.000	0.998	0.988	0.978	0.968	0.958
		-5	0.995	0.995	0.993	0.983	0.973	0.963	0.953
		-7.5	—	0.993	0.991	0.981	0.971	0.961	0.951
		-10	—	—	0.988	0.978	0.968	0.958	0.948
		-20	—	—	—	0.968	0.958	0.949	0.939
		-30	—	—	—	—	0.949	0.939	0.929

## 6-2. Models: AOYG45KRTA and AOYG54KRTA

**NOTE:** Values mentioned in the table are calculated based on the maximum capacity.

COOLING			Pipe length (m)						
			5	7.5	10	20	30	40	50
Height difference H (m)	Indoor unit is higher than outdoor unit *1	30	—	—	—	—	0.900	0.879	0.858
		20	—	—	—	0.937	0.915	0.894	0.872
		10	—	—	0.973	0.952	0.931	0.908	0.887
		7.5	—	0.988	0.977	0.956	0.934	0.913	0.891
		5	0.992	0.992	0.981	0.960	0.938	0.916	0.894
	Indoor unit is lower than outdoor unit *2	0	1.000	1.000	0.989	0.967	0.945	0.923	0.901
		-5	1.000	1.000	0.989	0.967	0.945	0.923	0.901
		-7.5	—	1.000	0.989	0.967	0.945	0.923	0.901
		-10	—	—	0.989	0.967	0.945	0.923	0.901
		-20	—	—	—	0.967	0.945	0.923	0.901
		-30	—	—	—	—	0.945	0.923	0.901

HEATING			Pipe length (m)						
			5	7.5	10	20	30	40	50
Height difference H (m)	Indoor unit is higher than outdoor unit *1	30	—	—	—	—	0.978	0.968	0.958
		20	—	—	—	0.988	0.978	0.968	0.958
		10	—	—	0.998	0.988	0.978	0.968	0.958
		7.5	—	1.000	0.998	0.988	0.978	0.968	0.958
		5	1.000	1.000	0.998	0.988	0.978	0.968	0.958
	Indoor unit is lower than outdoor unit *2	0	1.000	1.000	0.998	0.988	0.978	0.968	0.958
		-5	0.995	0.995	0.993	0.983	0.973	0.963	0.953
		-7.5	—	0.993	0.991	0.981	0.971	0.961	0.951
		-10	—	—	0.988	0.978	0.968	0.958	0.948
		-20	—	—	—	0.968	0.958	0.949	0.939
		-30	—	—	—	—	0.949	0.939	0.929

## 7. Additional charge calculation

### 7-1. Model: AOYG36KRTA

Refrigerant type		R32
Refrigerant amount	g	1,900

#### ■ Refrigerant charge

Total pipe length	m	30 or less	40	50 (Max.)	40 g/m
Additional charge amount	g	0	400	800	

### 7-2. Models: AOYG45KRTA and AOYG54KRTA

Refrigerant type		R32
Refrigerant amount	g	2,700

#### ■ Refrigerant charge

Total pipe length	m	30 or less	40	50 (Max.)	40 g/m
Additional charge amount	g	0	400	800	



## 8. Airflow

### 8-1. Models: AOYG36KRTA

#### ● Cooling

m <sup>3</sup> /h	3,750
l/s	1,042
CFM	2,207

#### ● Heating

m <sup>3</sup> /h	3,750
l/s	1,042
CFM	2,207

### 8-2. Models: AOYG45KRTA and AOYG54KRTA

#### ● Cooling

m <sup>3</sup> /h	4,450
l/s	1,236
CFM	2,619

#### ● Heating

m <sup>3</sup> /h	4,450
l/s	1,236
CFM	2,619

# 9. Operation noise (sound pressure)

## 9-1. Noise level curve

### Model: AOYG36KRTA

#### Cooling

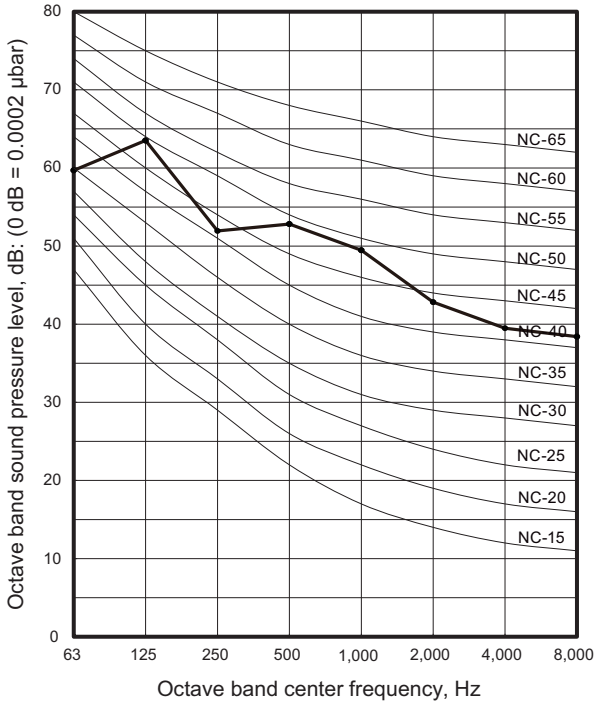

#### Heating

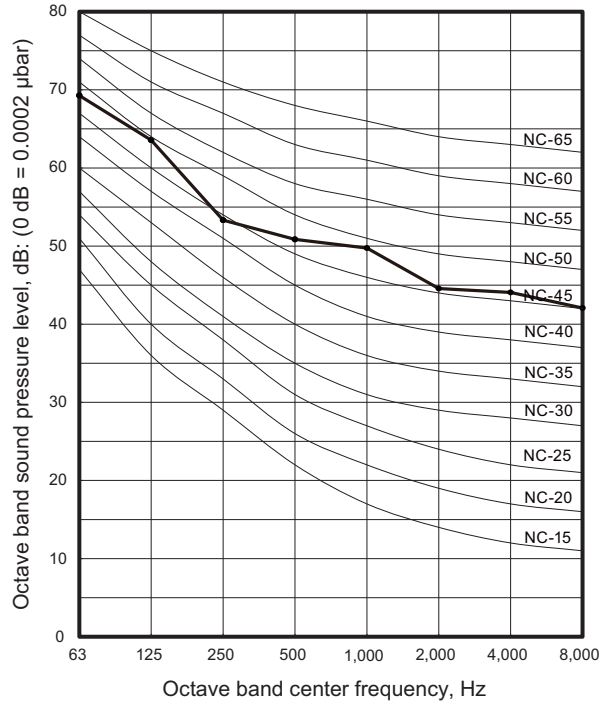

### Model: AOYG45KRTA

#### Cooling

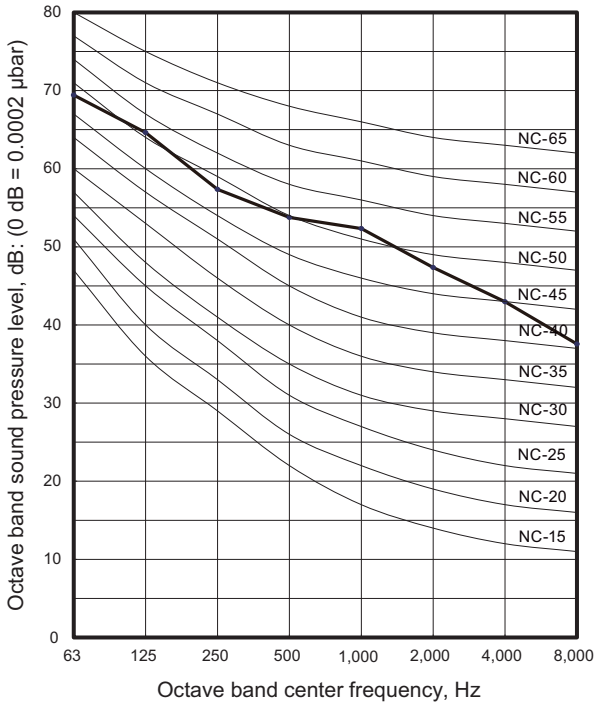

#### Heating

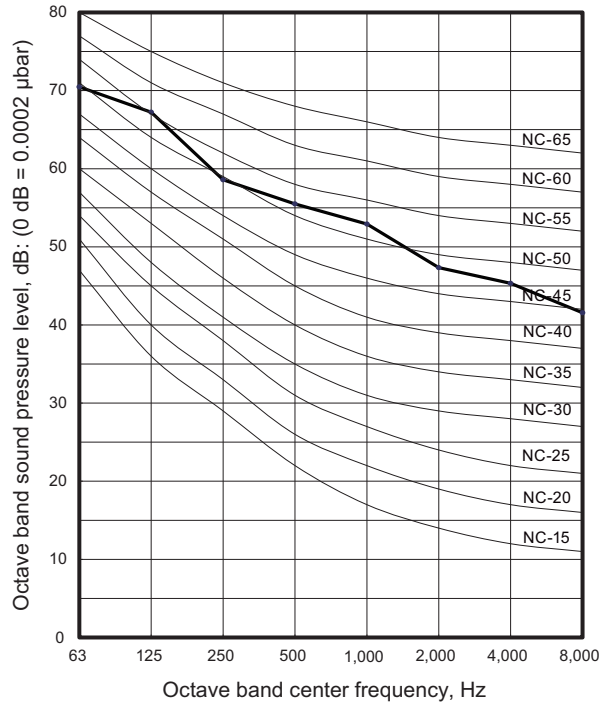

OUTDOOR UNIT  
AOYG36-54KRTA

OUTDOOR UNIT  
AOYG36-54KRTA

■ Model: AOYG54KRTA

● Cooling

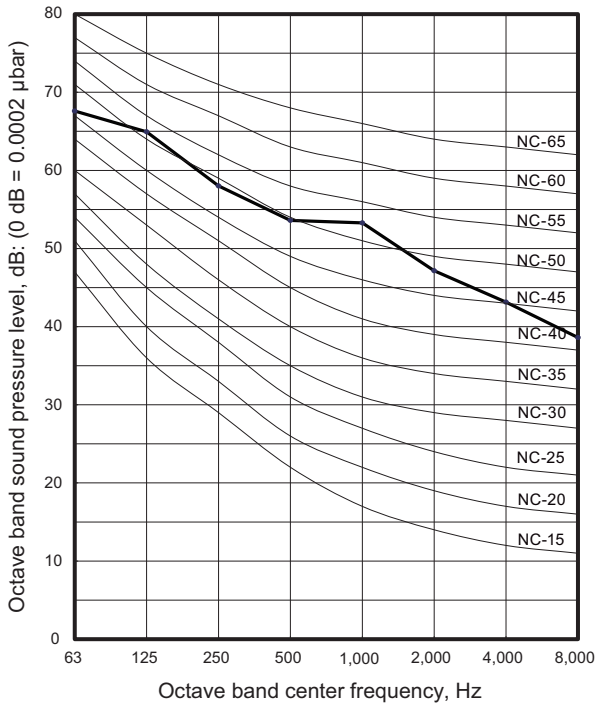

● Heating

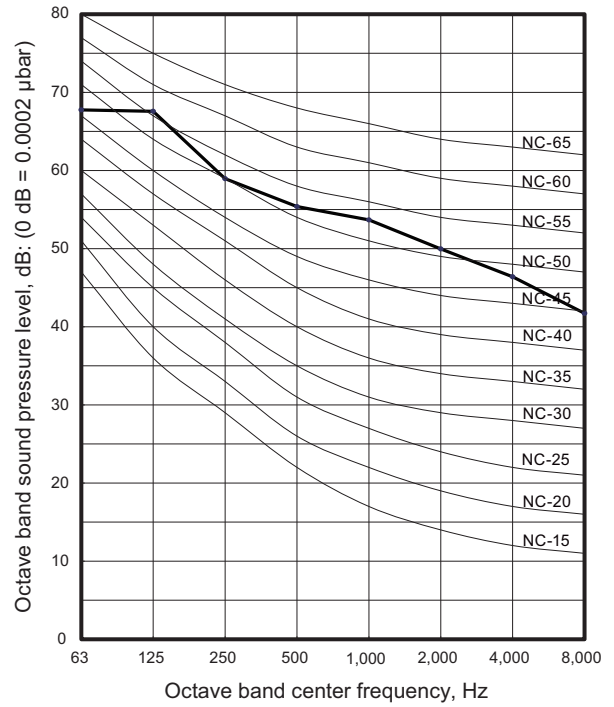

OUTDOOR UNIT  
AOYG36-54KRTA

OUTDOOR UNIT  
AOYG36-54KRTA

9-2. Sound level check point

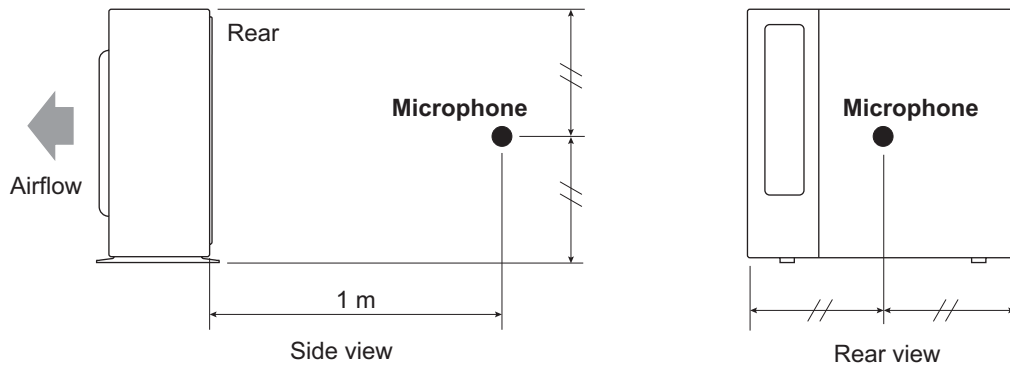

**NOTE:** Detailed shape of the actual outdoor unit might be slightly different from the one illustrated above.

## 10. Electrical characteristics

Model name			AOYG36KRTA	
Power supply	Voltage	V	3N 400 ~	
	Frequency	Hz	50	
Max operating current *1		A	10.5	
Starting current		A	5.5	
Wiring spec. *2	Circuit breaker current		A	16
	Power cable		mm <sup>2</sup>	2.5
	Connection cable *3	Cross-sectional area	mm <sup>2</sup>	1.5
		Limited wiring length	m	51

Model name			AOYG45KRTA	AOYG54KRTA
Power supply	Voltage	V	3N 400 ~	
	Frequency	Hz	50	
Max operating current *1		A	14.0	
Starting current		A	6.6	8.0
Wiring spec. *2	Circuit breaker current		A	16
	Power cable		mm <sup>2</sup>	2.5
	Connection cable *3	Cross-sectional area	mm <sup>2</sup>	1.5
		Limited wiring length	m	51

\*1: Maximum current is the total current of the indoor unit and the outdoor unit.

\*2: Selected sample based on Japan Electrotechnical Standards and Codes Committee E0005. As the regulations of wire size and circuit breaker differ in each country or region, select appropriate devices complied to the regional standard.

\*3: Limit voltage drop to less than 2%. Increase conductor size if voltage drop is 2% or more.

# 11. Safety devices

OUTDOOR UNIT  
AOYG36-54KRTA

OUTDOOR UNIT  
AOYG36-54KRTA

Type of protection	Protection form		Model
			AOYG36KRTA
Circuit protection	Current fuse (Main PCB)		250 V, 30 A × 2 250 V, 10 A × 2
Fan motor protection	Thermal protection program	Activate	122 ±9 °C Fan motor stop
		Reset	116 +10 <sub>-9</sub> °C Fan motor restart
Compressor protection	Thermal protection program (Discharge temp.)	Activate	110 °C Compressor stop
		Reset	After 7 minutes Compressor restart
	Thermal protection program (Compressor temp.)	Activate	108 °C Compressor stop
		Reset	80 °C or less Compressor restart
	Thermal protection program (Outdoor temp.)	Activate	-20 °C Compressor stop
		Reset	-15 °C Compressor restart

Type of protection	Protection form		Model
			AOYG45KRTA AOYG54KRTA
Circuit protection	Current fuse (Main PCB)		250 V, 30 A × 2 250 V, 10 A × 2
Fan motor protection	Thermal protection program	Activate	150 ±15 °C Fan motor stop
		Reset	120 ±15 °C Fan motor restart
Compressor protection	Thermal protection program (Discharge temp.)	Activate	110 °C Compressor stop
		Reset	After 7 minutes Compressor restart
	Thermal protection program (Compressor temp.)	Activate	108 °C Compressor stop
		Reset	80 °C or less Compressor restart
	Thermal protection program (Outdoor temp.)	Activate	-20 °C Compressor stop
		Reset	-15 °C Compressor restart

## 12. External input and output

With using external input and output functions, this product can be operated inter-connectedly with an external device.

Connector	Input	Output	Remarks
P580	Low noise mode	—	See external input/output settings for details.
PA580	Peak cut mode	—	
P590	—	Error status	
PA590	—	Compressor status	

### 12-1. External input

With using external input function, on/off status of “Low noise mode” and “Peak cut mode” can be specified by the external signal.

#### ■ Low noise mode

In following condition, the operating noise of the outdoor unit reduces comparing from the one in normal operating condition:

The air conditioner is set to the “Low noise mode” when closing the contact input of a commercial timer or on/off switch to a connector on the control PCB of the outdoor unit.

**NOTE:** Product performance may drop depending on some conditions such as the outdoor temperature.

#### • Circuit diagram example

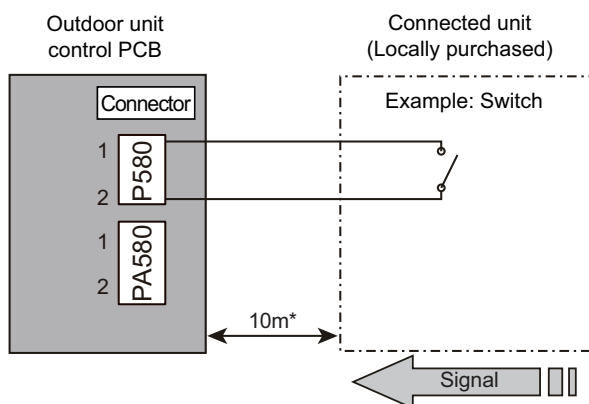

- Contact capacity: DC 24 V or more, 10 mA or more.
- \*: Make the distance from the PCB to the connected unit within 10 m.
- Construct a circuit as shown in this figure with using optional parts mentioned below.
- Input signal: On in “Low noise mode”
- Input signal: Off in normal operation
- To set the level of “Low noise mode”, refer to “Low noise mode” on page 67.

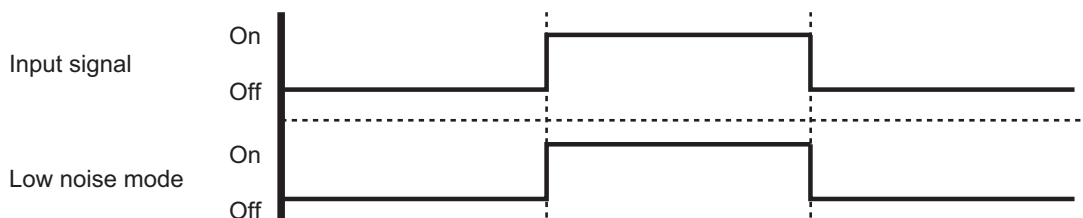

#### • Optional part

Part name	Model name	Exterior
External connect kit	UTY-XWZXZ3	External input wire 

## ■ Peak cut mode

By performing following on-site work, operation that suppresses the current value can be enabled: The air conditioner is set to the “Peak cut mode” when closing the contact input of a commercial timer or on/off switch to a connector on the control PCB of the outdoor unit.

### • Circuit diagram example

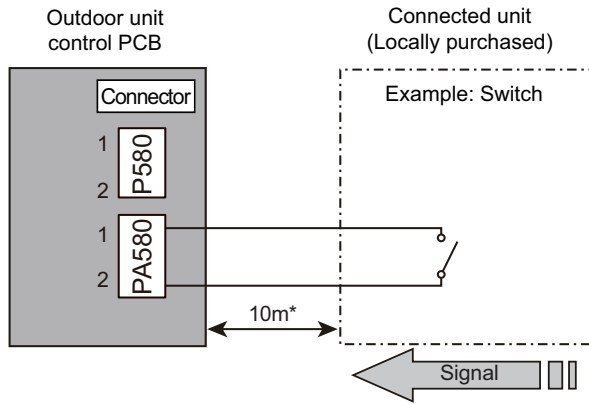

- Contact capacity: DC 24 V or more, 10 mA or more.
- \*: Make the distance from the PCB to the connected unit within 10 m.
- Construct a circuit as shown in this figure with using optional parts mentioned below.
- Input signal: On in “Peak cut mode”
- Input signal: Off in normal operation
- To set the level of “Peak cut mode”, refer to [“Peak cut mode”](#) on page 68.

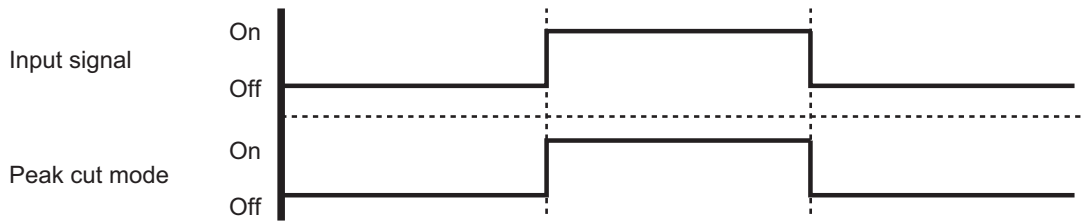

### • Optional part

Part name	Model name	Exterior
External connect kit	UTY-XWZXZ3	External input wire 

## 12-2. External output

With using external output function, some status signals are transmitted to the control PCB, and the related LED lamp indicates the status of this product.

### ■ Error status output

Signal on air conditioner error status is generated when a malfunction occurs.

- **Circuit diagram example**

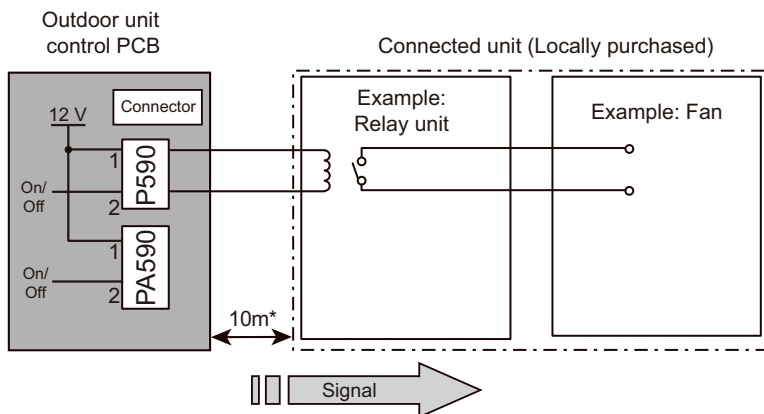

- Output voltage (Vcc): DC 12 V 50 mA or less
- \*: Make the distance from the PCB to the connected unit within 10 m.

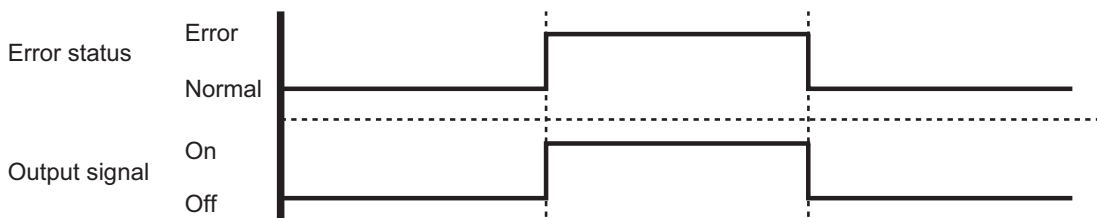

- **Optional part**

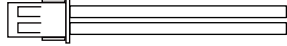
Part name	Model name	Exterior
External connect kit	UTY-XWZXZ3	External output wire 



## Compressor status output

Signal on compressor operation status is generated when the compressor is running.

### Circuit diagram example

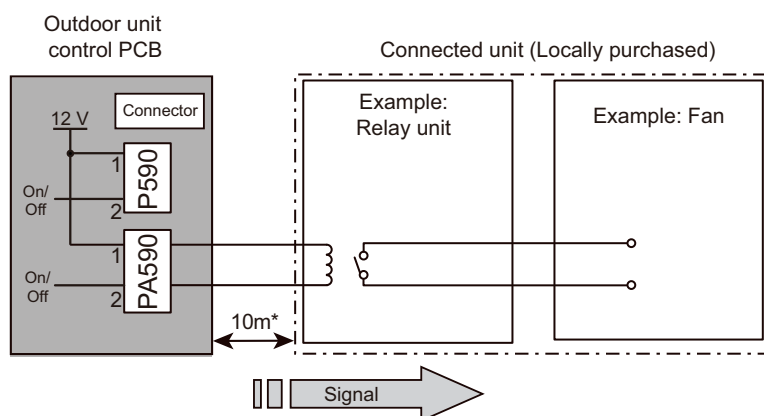

- Output voltage (Vcc): DC 12 V 50 mA or less
- \*: Make the distance from the PCB to the connected unit within 10 m.

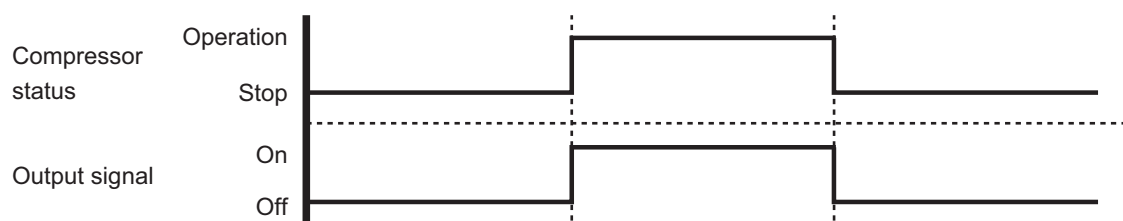

### Optional part

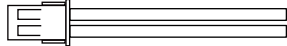
Part name	Model name	Exterior
External connect kit	UTY-XWZXZ3	External output wire 

## 13. Function settings

Perform appropriate function setting locally according to the installation environment.

**NOTE:** Incorrect settings can cause a product malfunction.

### ⚠ CAUTION

- Before setting up the switch buttons, discharge the static electricity from your body.
- Never touch the terminals or the patterns on the parts that are mounted on the PCB.

### 13-1. Control PCB and switch buttons location

Control PCB of the outdoor unit is located as shown in the following figure.

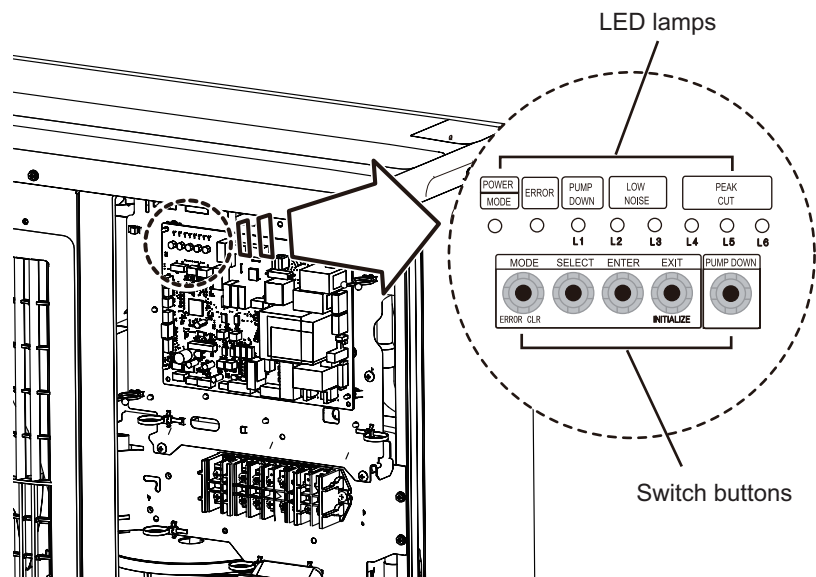

## Switch buttons and the functions

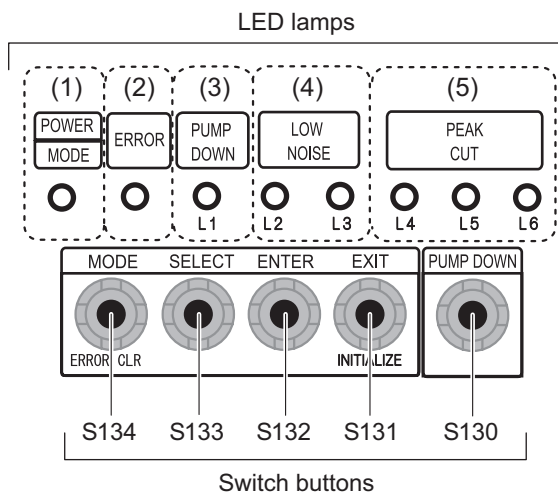

LED lamp			Function or operation method
(1)	POWER/MODE	Green	Lights on while power on. Local setting in outdoor unit or error code is displayed with blink.
(2)	ERROR	Red	Blinks during error operation.
(3)	PUMP DOWN (L1)	Orange	Lights on during pump down operation.
(4)	LOW NOISE MODE (L2 and L3)	Orange	Lights on during "Low noise mode" when local setting is activated. (Lighting pattern of L2 and L3 indicates low noise level.)
(5)	PEAK CUT MODE (L4, L5, and L6)	Orange	Lights on during "Peak cut mode" when local setting is activated. (Lighting pattern of L4, L5, and L6 indicates peak cut level.)

Switch button			Function or operation method
S134	MODE		Switches between "Local setting" and "Error code display".
S133	SELECT		Switches between the individual "Local settings" and the "Error code displays".
S132	ENTER		Switches between the individual "Local settings" and the "Error code displays".
S131	EXIT		Returns to "Operation status display".
S130	PUMP DOWN		Starts the pump down operation.

## 13-2. Local setting procedure

**NOTE:** Before performing the function setting, be sure to stop the operation of the air conditioner.

### Low noise mode

1. Press the MODE switch button (S134) for 3 seconds or more to switch to "Local setting mode".
2. After confirming the LED lamp of POWER/MODE blinks 9 times, press the ENTER switch button (S132).

POWER MODE	ERROR	PUMP DOWN (L1)	LOW NOISE (L2) (L3)		PEAK CUT (L4) (L5) (L6)		
Blinks (9 times)	○	○	○	○	○	○	○

Sign "○": Lights off

3. Press the SELECT switch button (S133), and adjust the LED lamp as shown below. Then the LED lamp indicates the current setting.

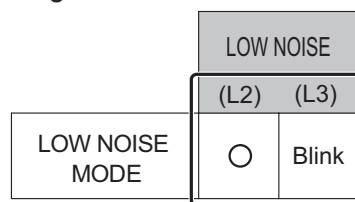

4. Press the ENTER switch button (S132).

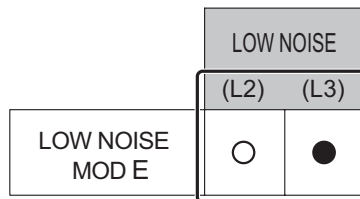

Sign "●": Lights on

5. Press the SELECT switch button (S133), and adjust the LED lamps as shown below.

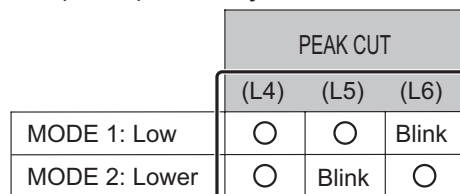

6. Press the ENTER switch button (S132) and fix it.

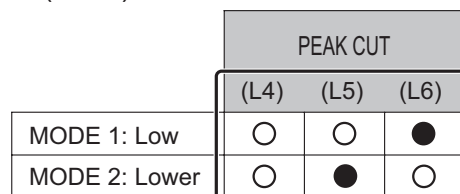

7. To return to "Operating status display (Normal operation)", press the EXIT switch button (S131).

#### In case of missing how many times you pressed the SELECT and ENTER switch buttons:

1. To return to "Operation status display (Normal operation)", press the EXIT switch button once.
2. Restart from the beginning of setting procedure.

**NOTE:** In case of missing how many times you pressed the SELECT and ENTER switch buttons, you must redo the setting procedure. Return to "Operation status display (Normal operation)" by pressing the EXIT switch button once, and restart from the beginning of the setting procedure.

## ■ Peak cut mode

1. Press the MODE switch button (S134) for 3 seconds or more to switch to “Local setting mode”.
2. After confirming the LED lamp of POWER/MODE blinks 9 times, press the ENTER switch button (S132).

POWER MODE	ERROR	PUMP DOWN (L1)	LOW NOISE		PEAK CUT		
			(L2)	(L3)	(L4)	(L5)	(L6)
Blinks (9 times)	○	○	○	○	○	○	○

Sign “○”: Lights off

3. Press the SELECT switch button (S133), and adjust the LED lamp as shown below. Then the LED lamp indicates the current setting.

PEAK CUT MODE	LOW NOISE	
	(L2)	(L3)
	Blink	○

4. Press the ENTER switch button (S132).

PEAK CUT MODE	LOW NOISE	
	(L2)	(L3)
	●	○

Sign “●”: Lights on

5. Press the SELECT switch button (S133), and adjust the LED lamps as shown below.

	PEAK CUT		
	(L4)	(L5)	(L6)
100 % of rated input ratio	○	○	Blink
75 % of rated input ratio	○	Blink	○
50 % of rated input ratio	○	Blink	Blink
0 % of rated input ratio	Blink	○	○

6. Press the ENTER switch button (S132) and fix it.





	PEAK CUT		
	(L4)	(L5)	(L6)
100 % of rated input ratio	○	○	●
75 % of rated input ratio	○	●	○
50 % of rated input ratio	○	●	●
0 % of rated input ratio	●	○	○

7. To return to “Operating status display (Normal operation)”, press the EXIT switch button (S131).

**NOTE:** When pressed number is lost during setting, you must redo the setting procedure. Return to “Operation status display (Normal operation)” by pressing the EXIT switch button once, and restart from the beginning of the setting procedure.

## 14. Accessories

### 14-1. Models: AOYG36KRTA, AOYG45KRTA, and AOYG54KRTA

Part name	Exterior	Q'ty	Part name	Exterior	Q'ty
Installation manual		1	Drain cap		3
Drain pipe		1	One-touch bush		2

## 15. Optional parts

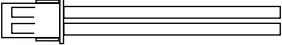
Exterior	Part name	Model name	Summary
 A technical drawing of an external connect kit, showing a rectangular connector with three pins on the left and two long, parallel tubes extending to the right.	External connect kit	UTY-XWZXZ3	Use to operate the external input and output functions of outdoor unit.